

## Advanced Dewatering Device

The Reflex Suction Strainer is designed to work in harsh, heavy duty, high traffic environments and provide contaminant reduced, long lasting, fast and reliable fluid transfer.



## ADVANCED *FLEXIBLE* DEWATERING



### Features

- > Reduced system downtime
- > Longer lasting
- > Fewer pump blockages
- > Decreased pump dry suction time
- > Less manual handling
- > Easy cleaning
- > Fast attachment and replacement
- > No additional fittings required
- > No need to bore drainage holes

### Benefits

- > No sharp edges
- > Reduced trip hazards
- > No metal parts
- > Lightweight
- > Hi Vis colour

## REFLEX Strainer

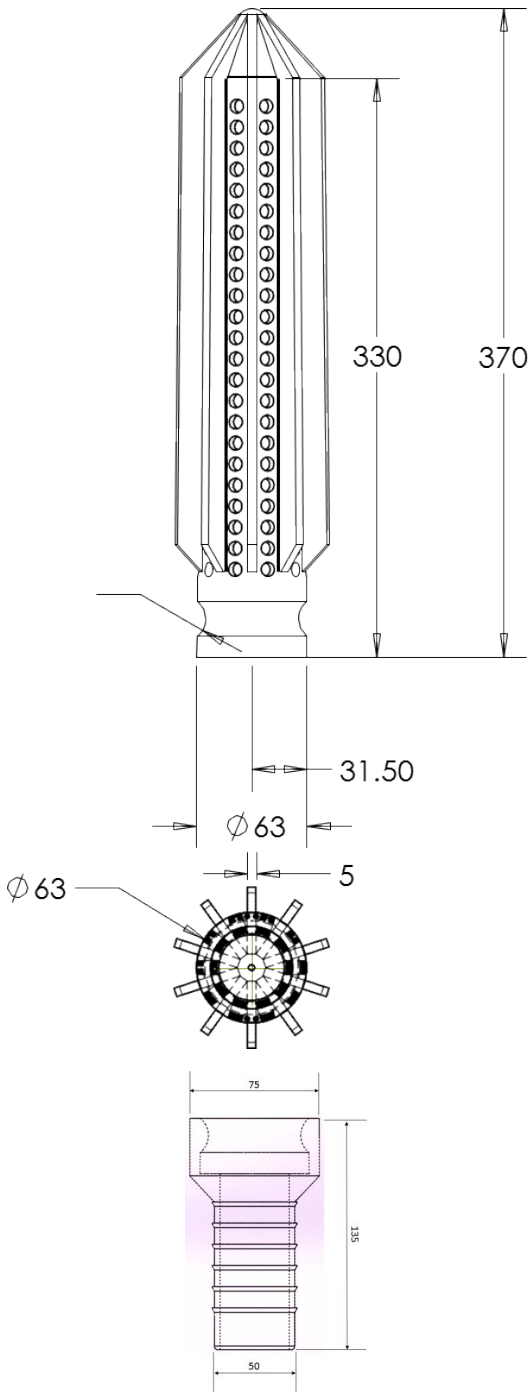

Flow rate	850 litres per minute
Filtration flow	Statistics 12 times surface area to suction aperture
Elongation	Safe capability 450%
Length	370mm
Width	63mm
Weight	approx. 450g
Hardness	65 shore A
Temperature range	Safe-66c to 100+c
Colour	Yellow (other colours on request)
Size	2" standard other sizes available on request.

Vulcanized elastomeric compound(SBR)

Manufactured in accordance to ISO9000

Supports in excess of 100 tonnes of downward pressure

Petrochemical resistant

No sharp edges

No metal parts

No corrosion



Fast attachment/detachment to Camlock fitting.



Reflex adapter is chemically bonded to the strainer. Just slide the hose over the male end. No hose clamps needed.

### Pumps 2000 (International)

6-12 Burleigh Street  
Toronto 2283  
N.S.W., Australia  
Tel: +61 2 49599400  
Fax: +61 2 49504927  
info@pumps2000.com

### Pumps 2000 (America)

1721 Main Street  
Pittsburgh, PA 15215  
Tel: 412.963.9200  
1.800.245.6211  
Fax: 412.963.9214  
info@pumps2000america.com

### Pumps 2000 (Europe)

Sunderland  
Tyne & Wear, SR1 2NQ  
United Kingdom  
Tel: +44 (0) 191 5675488  
Fax: +44 (0) 191 5678512  
info@pumps2000europe.com

