

PUMPS 2000 - 2 inch SLURRY VALVE

PNEUMATIC DIAPHRAGM PUMP

Flow Rate : 0-553 L/min

Air Pressure : Up to 100 psi

Fluid Port : 2 inch (Internal Thread)

Air Inlet Port : 1/2 inch (Internal Thread)

Exhaust Port: 3/4 inch (Internal Thread)

Delivery Pressure : Tested to 600 kPa

Suction Pressure : Tested to -92 kPa

Maximum Dry Suction : -77 kPa

Particle Size : Maximum 46 mm \varnothing Suspended Solids

Weight : From 19.5 kg

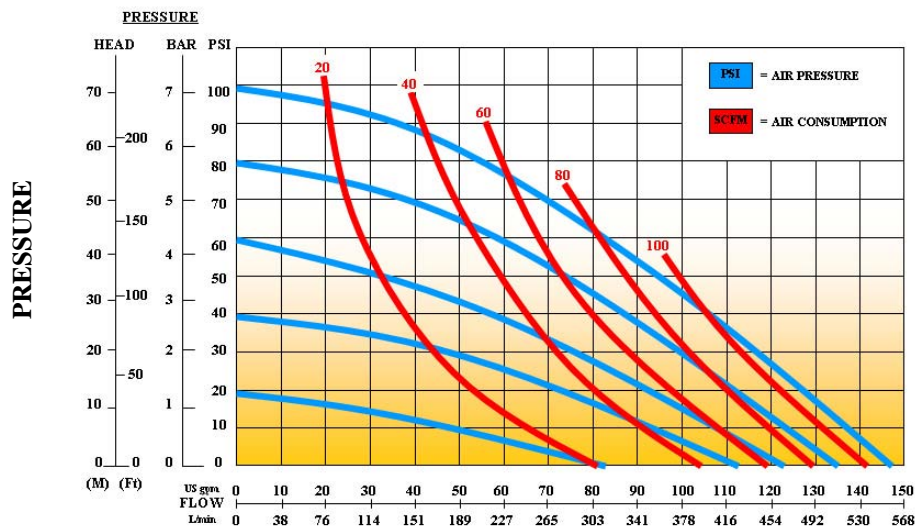
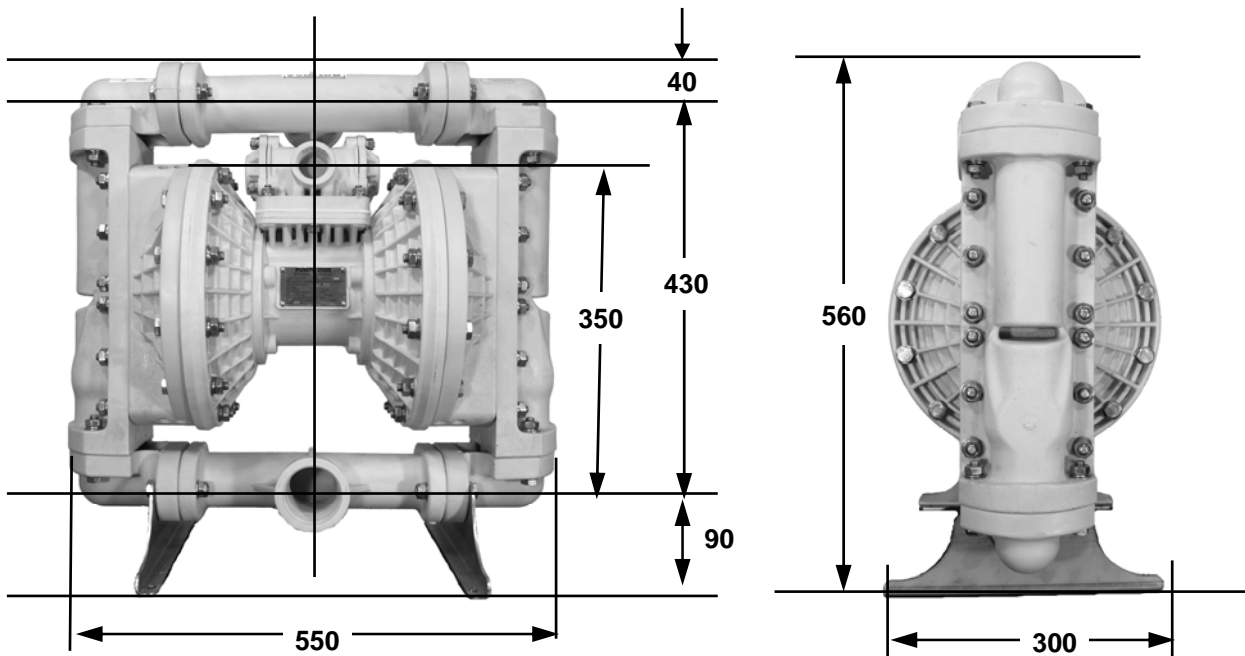

Do Not Exceed 125 PSI Air Supply Pressure

PUMP CAPACITY