

PUMPS 2000 - 1.5 inch BALL VALVE

PNEUMATIC DIAPHRAGM PUMP

Flow Rate : 0—300 L/min

Air Pressure : Up to 100 psi

Fluid Connection : 1 1/2 inch - Internal Thread

Air Inlet Connection : 1/2 inch - Internal Thread

Air Exhaust Connection : 3/4 inch - Internal Thread

Delivery Pressure : Tested to 600 kPa

Suction Pressure : Tested to -93 kPa

Maximum Dry Suction : -57 kPa

Particle Size : Up to 12 mm ϕ Suspended Solids

Weight : From 14 kg

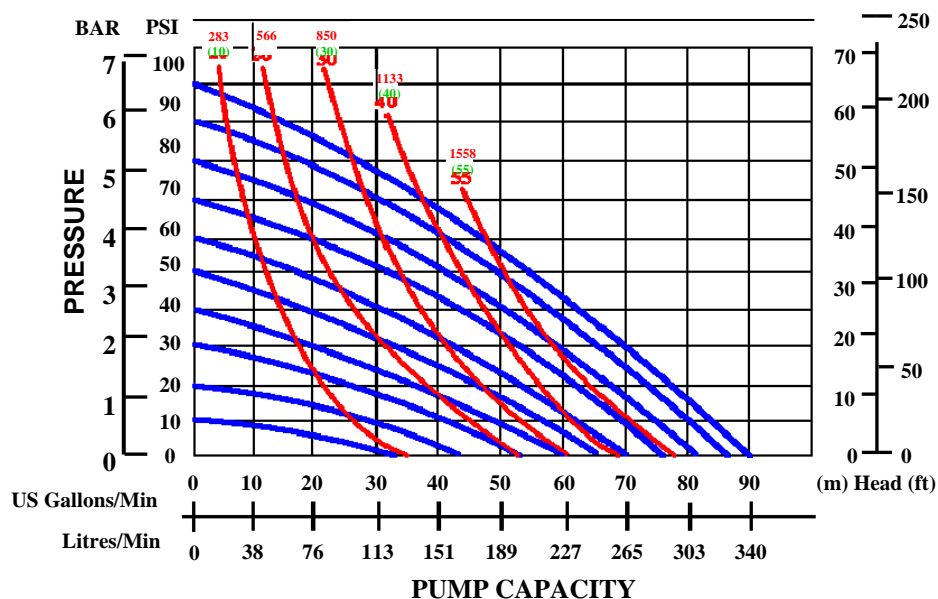
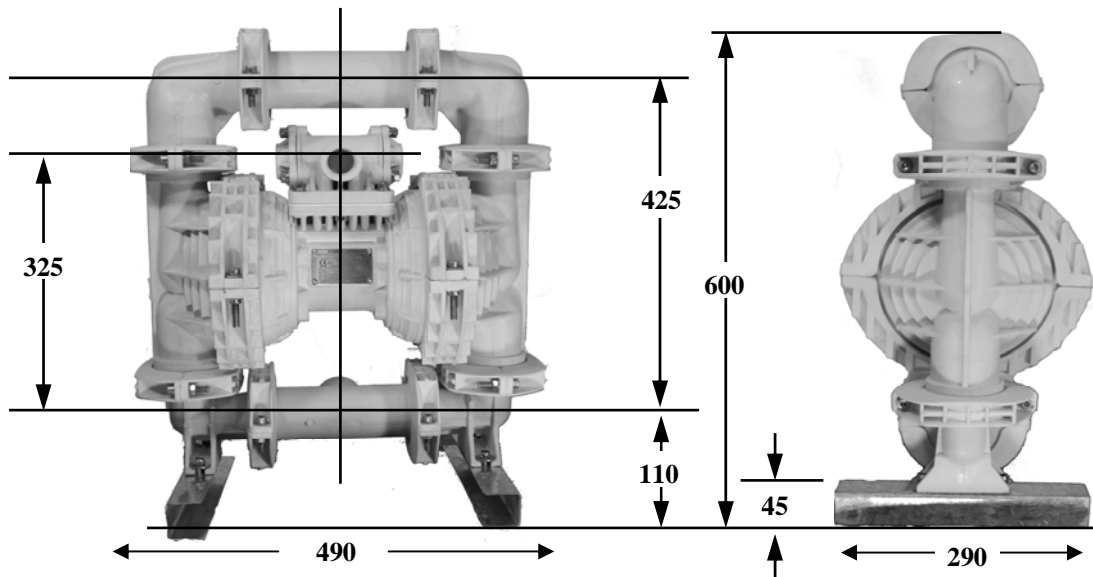

Do Not Exceed 125 PSI Air Supply Pressure

■ = AIR PRESSURE

■ = AIR CONSUMPTION l/min (cfm)