

PUMPS 2000 - 1 inch SLURRY VALVE

PNEUMATIC DIAPHRAGM PUMP

- Flow Rate :** 0-222 L/min
- Air Pressure :** Up to 100 psi
- Fluid Connection :** 1 inch (Internal Thread)
- Air Inlet Connection :** ½ inch (Internal Thread)
- Air Exhaust Connection :** ¾ inch (Internal Thread)
- Delivery Pressure :** Tested to 600 kPa
- Suction Pressure :** Tested to -92 kPa
- Maximum Dry Suction :** -60 kPa
- Particle Size :** Up to 20 mm ø Suspended Solids
- Weight :** From 7.5 kg

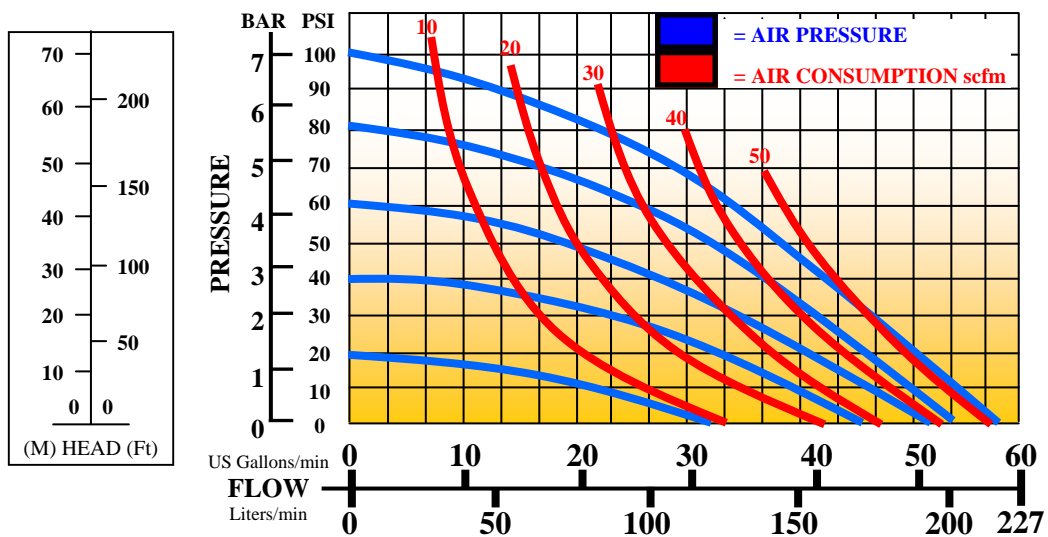
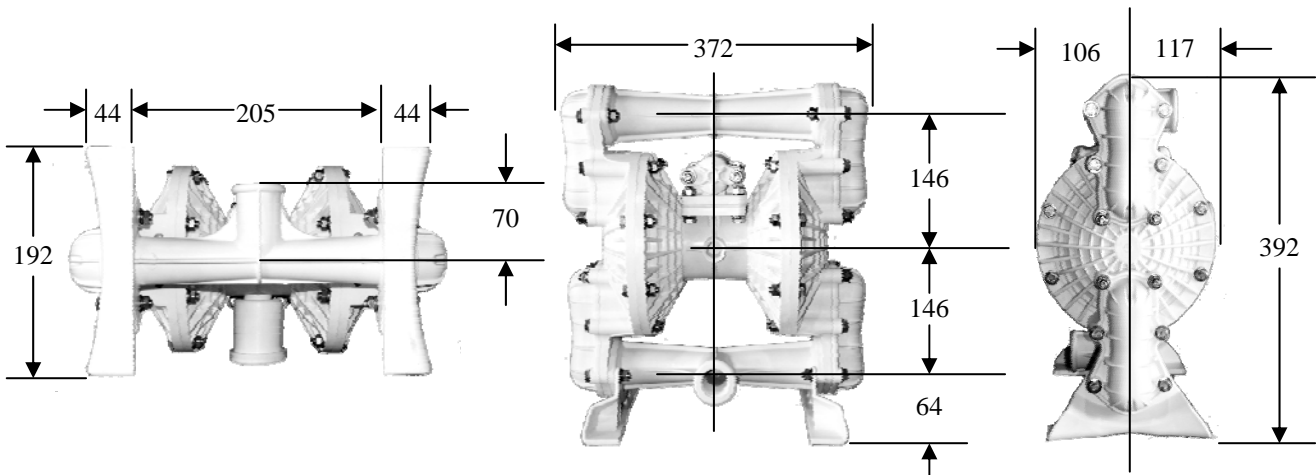

Do Not Exceed 125 PSI Air Supply Pressure